

Whole House Heat Recovery



The heat recovery units for the whole house have been specifically designed to eliminate excessive moisture and so helping to prevent condensation with the inherent risks to property and health whilst retaining up to 80% of heat contained within the outgoing air.

The Whole House System is designed to run continuously on low speed and when required can be switched to high speed via a single remote switch. (supplied separately)

Alternatively, it is also possible to control the unit with remote switched-live feeds taken from, for example, bathroom, en-suite or kitchen lights. Up to 4 switched-lives can be accommodated using a Relay Box control unit. (available separately)

- ✿ Loft / Void Mounted
- ✿ Energy Saving
- ✿ Recovers up to 80% of heat that would be otherwise lost
- ✿ 2 year no quibble guarantee
- ✿ Simple Installation
- ✿ 

Installation

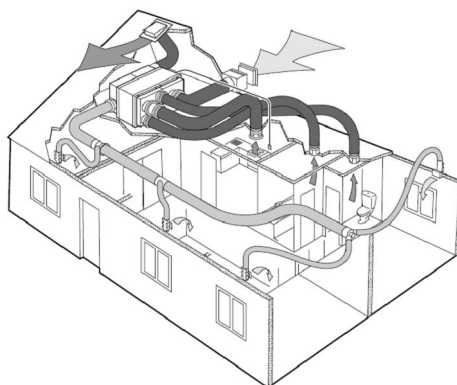

Technical Data

230V model

Catalogue No.	Type
HRWH	2-speed supply / extract continuous trickle with boost

Construction:	The units are made of strong and durable self extinguishing plastic for strength, durability and
----------------------	--

	finish.
Electrical:	220 - 230V ~ A.C. 50Hz Single phase consuming 30/70 watts. The units do not require an earth. All wiring must comply with current IEE regulations. A double pole isolating switch, having a contact separation of at least 3mm in all poles, must be used with a 3 amp fuse fitted.

Guarantee: - Two year no quibble guarantee.

Dimensions

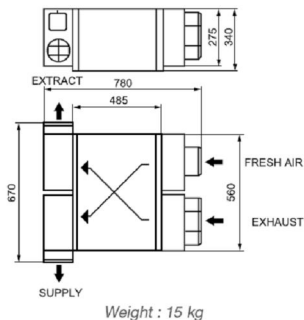

Performance

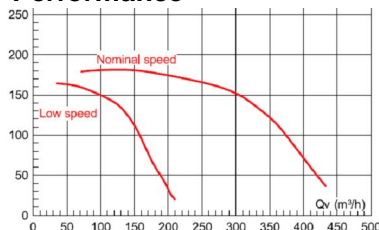

Air Volume High	430 m ³ /h
Air Volume Low	220 m ³ /h
Sound	High 48dB, Low 39dB
Voltage	220-230AC~
Frequency	50Hz
Wattage	70W (HIGH) 30W (LOW)
Max. Temp.	50 °C
Weight	15.0 kg
Max Pressure	180 pa

Additional Data

When the Whole House System is in operation, the warm, stale air is drawn from the dwelling - usually bathrooms, en-suites or kitchens.

When stale air enters the Whole House Unit, it passes through the extraction filter which helps keep the fan and heat exchange matrix clean.

The fresh air enters the Whole House Unit via the fresh air inlet grille/manifold and passes through the inlet filter so that much of the airborne dust and pollen can be removed.

The stale and fresh air then pass through the heat exchange matrix where an amount of heat from the stale air is transferred to the incoming fresh air.

The fresh air is then ducted into the dwelling and the stale air is discharged to the outside.

Required ducting is sold separately.

Heat Exchanger Efficiency

